

JTS-NX7, JTS-NX8

Type : Dynamic (moving coil)

Frequency Response : 50 to 16,500Hz
(see Figure 11 ~ 12)

Polar Pattern : Cardioid, rotationally symmetrical about microphone axis, uniform with frequency
(see Figure 13 ~ 14)

Output Level (at 1,000Hz) : Open circuit voltage : -72dB*
(0.25mv) *0dB=1V/μbar

Impedance : Rated impedance is 600Ω for connection to microphone inputs rated low Z

Phasing : Positive pressure on diaphragm produces Positive voltage on pin 2 with respect to pin 3

Connector : Three-pin professional audio connector (male XLR type)

Case : Metallic enamel-painted die cast metal with hardened, matte-finished steel grille

Net Weight : NX-7 235 grams (8.3 oz)
NX-8 245 grams (8.6 oz)

Touch Noise : Super low



NX-7



NX-8

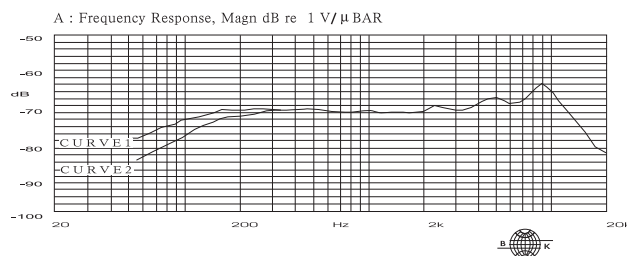

JTS-NX7 CURVE 1 : 0 degree, 5cm
CURVE 2 : 0 degree, 50cm

TYPICAL FREQUENCY RESPONSE
FIGURE 11

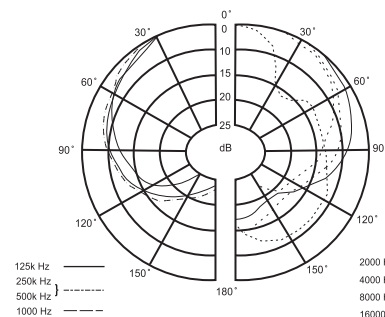

JTS-NX7 TYPICAL FREQUENCY RESPONSE
FIGURE 13

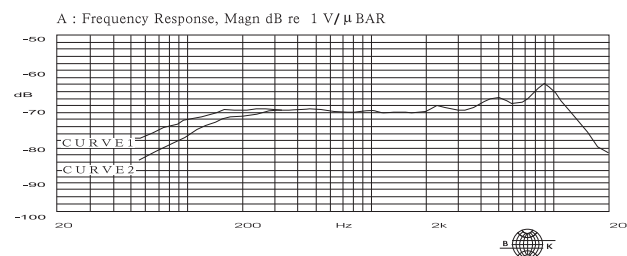

JTS-NX8 CURVE 1 : 0 degree, 5cm
CURVE 2 : 0 degree, 50cm

TYPICAL FREQUENCY RESPONSE
FIGURE 12

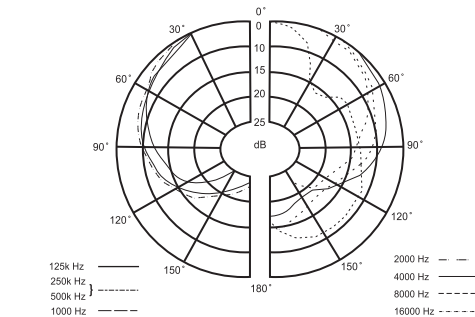

JTS-NX8 TYPICAL FREQUENCY RESPONSE
FIGURE 14

Specification and user's guide of JTS NX-series performance microphones.



Application :

- JTS NX-2** Kick Drum, Guitar & Bass Acoustic Bass.
- JTS NX-6** Tom-Toms, Snare Drum, Guitar & Bass Amplifiers, Brass & wood winds, Conga, Saxophone.
- JTS NX-7** Tom-Toms, Snare Drum, Guitar & Bass Amplifiers, Conga, Brass & wood winds, Saxophone, Acoustic Guitar.
- JTS NX-8** Performance vocal.

Microphon placement :

Tom-Toms	Snare Drum	Kick Drum	Guitar & Bass Amplifiers	Brass	Wood Winds	Electronic Bass Amplifier
1~3in (2.5~7.5cm)	1~3in (2.5~7.5cm)	2~10in (5~25cm)	2~10in (5~25cm)	1~3ft (30~100cm)	1~5in (2.5~12.5cm)	1~5in (2.5~12.5cm)

Note :

1. When using a handheld microphone please always hold the microphone body. Holding the grille might cause howling.
2. The miking effect will vary according to the distance between sound source and the microphone. (proximity effect).
3. When using a vocal microphone the optimal distance between mouth and a microphone is between 2.5~15cm (1~6 inches).
4. Miking is a technique and an art. Always try to find your favorable miking method.

JTS-NX2

Type : Dynamic (moving coil)

Frequency Response : 20 to 12,000Hz
(see Figure 7)

Polar Pattern : Cardioid, rotationally symmetrical about microphone axis, uniform with frequency (see Figure 8)

Output Level (at 1,000Hz) : Open circuit voltage : -85dB* (0.056mV)
*0dB=1V/μ bar

Impedance : Rated impedance is 600Ω for connection to microphone inputs rated low Z

Phasing : Positive pressure on diaphragm produces Positive voltage on pin 2 with respect to pin 3

Connector : Three-pin professional audio connector (male XLR type)

Case : Metallic enamel-painted die cast metal with hardened, matte-finished steel grille

Adjustable Locking Mount : (see Figure 1 ~ Figure 6)

Net Weight : 815 grams (28.75 oz)

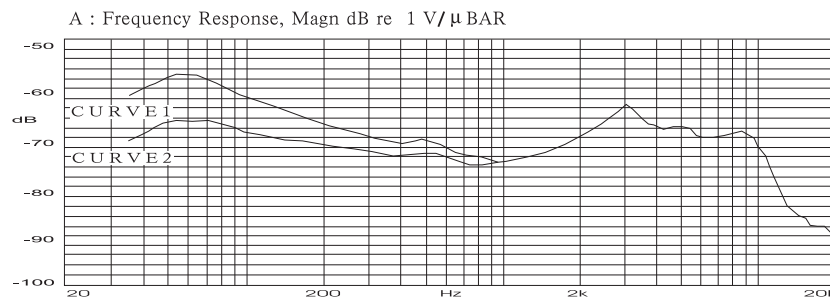
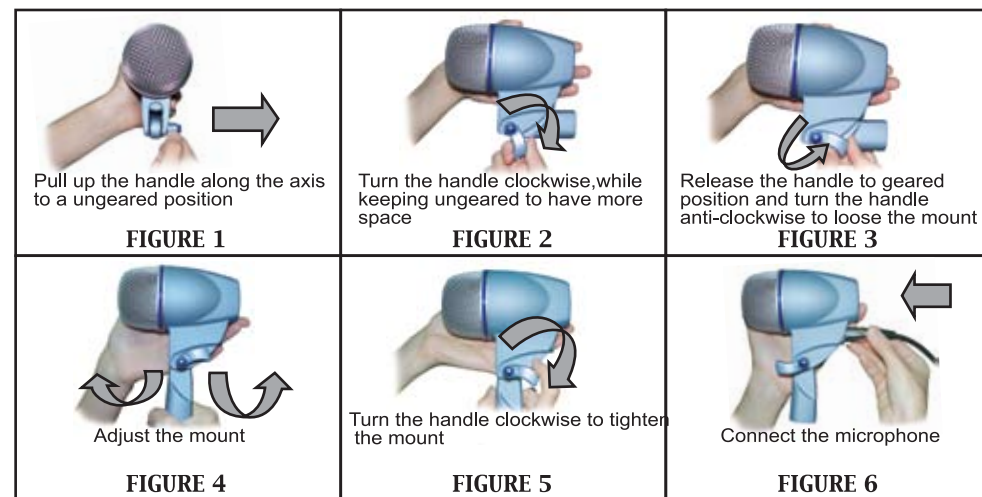

CURVE 1 : 0 degree, 5cm
CURVE 2 : 0 degree, 50cm

TYPICAL FREQUENCY RESPONSE
FIGURE 7

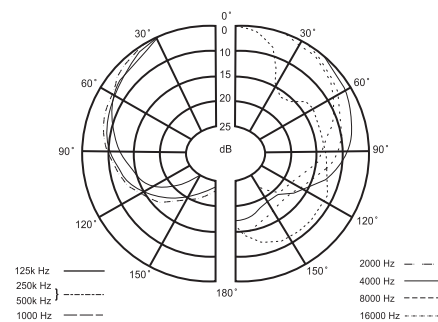

TYPICAL FREQUENCY RESPONSE
FIGURE 8

NX-Series Microphone

JTS-NX6

Type : Dynamic (moving coil)

Frequency Response : 60 to 16,000Hz
(see Figure 9)

Polar Pattern : Supercardioid, rotationally symmetrical about microphone axis, uniform with frequency (see Figure 10)

Output Level (at 1,000Hz) : Open circuit voltage : -72dB* (0.25mv)
*0dB=1V/μ bar

Impedance : Rated impedance is 600Ω for connection to microphone inputs rated low Z

Phasing : Positive pressure on diaphragm produces Positive voltage on pin 2 with respect to pin 3

Connector : Three-pin professional audio connector (male XLR type)

Case : Metallic enamel-painted die cast metal with hardened, matte-finished steel grill

Adjustable Locking Mount : (see Figure 1 ~ Figure 6)

Net Weight : 610 grams (21.51 oz)

Touch Noise : Super low

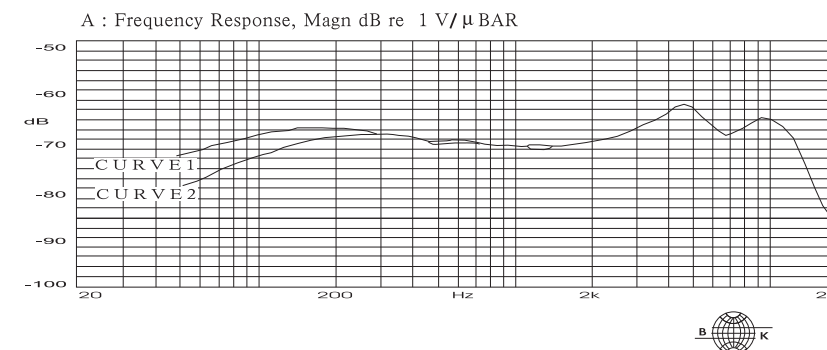

CURVE 1 : 0 degree, 5cm
CURVE 2 : 0 degree, 50cm

TYPICAL FREQUENCY RESPONSE
FIGURE 9

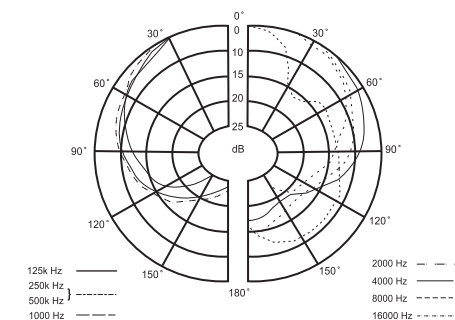

TYPICAL FREQUENCY RESPONSE
FIGURE 10



NX-Series Microphone