

Test Verification of Conformity

On the basis of the referenced test report(s), the sample(s) of the below product has been found to comply with the relevant harmonized standard(s) to the directive(s) listed on this verification at the time the tests were carried out. The manufacturer may indicate compliance to said directive(s) by signing a DoC himself and applying the CE-marking to products identical to the tested sample(s). In addition, the manufacturer shall file and keep the documentation according to the rules of the applicable directive(s) and shall consider changes of the standard(s) if relevant. Additional requirements may be applicable such as additional directives or local laws.

Applicant Name & Address : Precision Mastech Enterprises Co.
Room 1708-1709, Hewlett Centre, 54 Hoi Yuen Road, Kwun Tong, Kowloon, Hong Kong

Product(s) Tested : MS2203: Three Phase Digital Power Clamp Meter
MS2205: Harmonic Power Clamp Meter

Ratings and principal characteristics : Power: 4x1,5 V AA battery
Measure: 600 V, CAT III

Model(s) : MS2203, MS2205

Brand name : MASTECH

Relevant Standard(s) / Specification(s) / Directive(s) : EN 61326-1: 2006/ Electrical equipment for measurement, control and laboratory use – EMC requirements Part 1: General requirements
EN 61326-2-2: 2006/ Electrical equipment for measurement, control and laboratory use – EMC requirements Part 2-2: Particular requirements – Test configuration, operational conditions and performance criteria for portable test, measuring and monitoring equipment used in low-voltage distribution systems
EMC Directive 2004/108/EC

Verification Issuing Office Name & Address : Same as Legal Entity

Verification/Report Number(s) : GZ09010114-1/GZ09010114-1

Note 1 : This verification is part of the full test report(s) and should be read in conjunction with it.

This Verification is for the exclusive use of Intertek's Client and is provided pursuant to the agreement between Intertek and its Client. Intertek's responsibility and liability are limited to the terms and conditions of the agreement. Intertek assumes no liability to any party, other than to the Client in accordance with the agreement, for any loss, expense or damage occasioned by the use of this Verification. Only the Client is authorized to copy or distribute this Verification. Any use of the Intertek name or one of its marks for the sale or advertisement of the tested material, product or service must first be approved in writing by Intertek. The observations and test results referenced from this Verification are relevant only to the sample tested. This Verification by itself does not imply that the material, product, or service is or has ever been under an Intertek certification program.

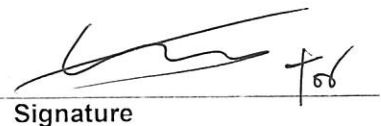

Signature

Name: Yannie Wang
Position: Assistant Manager
Date: 15 May, 2009

TEST REPORT

Applicant Name & Address : Precision Mastech Enterprises Co.
Room 1708-1709, Hewlett Centre, 54 Hoi Yuen Road, Kwun Tong, Kowloon,
Hong Kong

Manufacturing Site : Dongguan Huayi Mastech Co., Ltd.
Yulianwei Industrial Area, Qingxi Town, Dongguan, China

Sample Description
Product : MS2203: Three Phase Digital Power Clamp Meter
MS2205: Harmonic Power Clamp Meter

Model No. : MS2203, MS2205

Electrical Rating : 4×1,5V AA, 600 V, CAT III

Date Received : 24 January 2009

Date Test Conducted : 24 January 2009-14 April 2009

Test standards : EN 61326-1: 2006
EN 61326-2-2: 2006

Test Result : Pass

Conclusion : The submitted samples complied with the above EMC standards.

Remark : None.

*****End of Page*****

Prepared and Checked By:***Approved By:***

Bill Lin
Project Engineer
Intertek Guangzhou



Carrie Chen
Project Engineer
Intertek Guangzhou

15 May 2009 **Date**

This report is for the exclusive use of Intertek's Client and is provided pursuant to the agreement between Intertek and its Client. Intertek's responsibility and liability are limited to the terms and conditions of the agreement. Intertek assumes no liability to any party, other than to the Client in accordance with the agreement, for any loss, expense or damage occasioned by the use of this report. Only the Client is authorized to permit copying or distribution of this report and then only in its entirety. Any use of the Intertek name or one of its marks for the sale or advertisement of the tested material, product or service must first be approved in writing by Intertek. The observations and test results in this report are relevant only to the sample tested. This report by itself does not imply that the material, product, or service is or has ever been under an Intertek certification program. The test report only allows to be revised within three years from its original issued date unless further standard or the requirement was noticed.

Intertek Testing Services Shenzhen Ltd. Guangzhou Branch
Block E, No.7-2 Guang Dong Software Science Park, Caipin Road, Guangzhou Science City, GETDD Guangzhou, China
Tel / Fax: 86-20-8213 9688/86-20-3205 7538

CONTENT

- TEST REPORT 1**
- CONTENT 2**
- 1 TEST RESULTS SUMMARY 4**
- 2 EMC RESULTS CONCLUSION 5**
- 3 LABORATORY MEASUREMENTS 6**
- 4 EMI TEST 7**
 - 4.1 CONTINUOUS CONDUCTED DISTURBANCE VOLTAGE TEST 7
 - 4.1.1 Used Test Equipment 7
 - 4.1.2 Block Diagram of Test Setup 7
 - 4.1.3 Test Setup and Procedure 7
 - 4.1.4 Test Data 7
 - 4.1.5 Emission Curve 7
 - 4.1.6 Measurement Uncertainty 8
 - 4.2 DISCONTINUOUS CONDUCTED DISTURBANCE VOLTAGE 8
 - 4.2.1 Used Test Equipment 8
 - 4.2.2 Block Diagram of Test Setup 8
 - 4.2.3 Test Setup and Procedure 8
 - 4.2.4 Test Data 8
 - 4.2.5 Measurement Uncertainty 8
 - 4.3 RADIATED EMISSION 9
 - 4.3.1 Used Test Equipment 9
 - 4.3.2 Block Diagram of Test Setup 9
 - 4.3.3 Test Setup and Procedure 9
 - 4.3.4 Test Data 10
 - 4.3.5 Test Curve 12
 - 4.3.6 Measurement uncertainty 15
- 5 HARMONIC OF CURRENT 16**
 - 5.1 USED TEST EQUIPMENT 16
 - 5.2 BLOCK DIAGRAM OF TEST SETUP 16
 - 5.3 TEST SETUP AND PROCEDURE 16
 - 5.4 TEST DATA 16
 - 5.5 MEASUREMENT UNCERTAINTY 16
- 6 FLICKER 17**
 - 6.1 USED TEST EQUIPMENT 17
 - 6.2 BLOCK DIAGRAM OF TEST SETUP 17
 - 6.3 TEST SETUP AND PROCEDURE 17
 - 6.3.1 Definition 17
 - 6.3.2 Test condition 17
 - 6.4 TEST DATA 17
 - 6.5 MEASUREMENT UNCERTAINTY 17
- 7 EMS TEST 18**
 - 7.1 IEC 61000-4-2(PURSUANT TO EN 61326) ELECTROSTATIC DISCHARGE IMMUNITY 18
 - 7.1.1 Used Test Equipment 18
 - 7.1.2 Block Diagram of Test Setup 19
 - 7.1.3 Test Setup and Procedure 19
 - 7.1.4 Test Result 21

7.2	IEC 61000-4-6(PURSUANT TO EN 61326) INJECTED CURRENT (0.15 MHZ TO 80 MHZ).....	22
7.2.1	Used Test Equipment.....	22
7.2.2	Block Diagram of Test Setup.....	22
7.2.3	Test Setup and Procedure.....	22
7.2.4	Test Result	23
7.3	IEC 61000-4-4(PURSUANT TO EN 61326) ELECTRICAL FAST TRANSIENT/BURST	23
7.3.1	Used Test Equipment.....	23
7.3.2	Block Diagram of Test Setup.....	23
7.3.3	Test Setup and Procedure.....	24
7.3.4	Test Result	24
7.4	IEC 61000-4-5(PURSUANT TO EN 61326) SURGE IMMUNITY	25
7.4.1	Used Test Equipment.....	25
7.4.2	Block Diagram of Test Setup.....	25
7.4.3	Test Setup and Procedure.....	25
7.4.4	Test Result	26
7.5	IEC 61000-4-11(PURSUANT TO EN 61326) VOLTAGE DIPS AND INTERRUPTIONS	26
7.5.1	Used Test Equipment.....	26
7.5.2	Block Diagram of Test Setup.....	26
7.5.3	Test Setup and Procedure.....	26
7.5.4	Test Result	27
7.6	IEC 61000-4-3(PURSUANT TO EN 61326) RADIATED ELECTROMAGNETIC FIELD IMMUNITY	28
7.6.1	Used Test Equipment.....	28
7.6.2	Block Diagram of Test Setup.....	28
7.6.3	Test Setup and Procedure.....	29
7.6.4	Test Result	30
7.7	IEC 61000-4-8(PURSUANT TO EN 61326) POWER FREQUENCY MAGNETIC FIELD IMMUNITY.....	31
7.7.1	Used Test Equipment.....	31
7.7.2	Block Diagram of Test Setup.....	31
7.7.3	Test Setup and Procedure.....	31
7.7.4	Test Result	32
8	APPENDIX I - PHOTOS OF TEST SETUP.....	33
9	APPENDIX II - PHOTOS OF EUT	35

1

TEST RESULTS SUMMARY

Test Item	Standard	Result
Continuous Conducted Disturbance Voltage	EN 61326-1: 2006, EN 61326-2-2: 2006 Reference: CISPR 11: 2003	N/A
Discontinuous Conducted Disturbance Voltage	EN 61326-1: 2006, EN 61326-2-2: 2006 Reference: CISPR 11: 2003	N/A
Radiated Emission	EN 61326-1: 2006, EN 61326-2-2: 2006 Reference: CISPR 11: 2003	Pass
Harmonic of Current	EN 61326-1: 2006, EN 61326-2-2: 2006 Reference: IEC 61000-3-2:2000	N/A
Flicker	EN 61326-1: 2006, EN 61326-2-2: 2006 Reference: IEC 61000-3-3: 1994+A1: 2001	N/A
ESD Immunity	EN 61326-1: 2006, EN 61326-2-2: 2006 Reference: IEC 61000-4-2: 1995+A1: 1998+A2: 2000	Pass
EFT Immunity	EN 61326-1: 2006, EN 61326-2-2: 2006 Reference: IEC 61000-4-4:2004	N/A
Surge Immunity	EN 61326-1: 2006, EN 61326-2-2: 2006 Reference: IEC 61000-4-5:1995+A1: 2000	N/A
Inject Current Immunity	EN 61326-1: 2006, EN 61326-2-2: 2006 Reference: IEC 61000-4-6: 2003	N/A
Radiated Electromagnetic Field Immunity	EN 61326-1: 2006, EN 61326-2-2: 2006 Reference: IEC 61000-4-3: 2002	Pass
Power Frequency Magnetic Filed Immunity	EN 61326-1: 2006, EN 61326-2-2: 2006 Reference: IEC 61000-4-8:1993+A1:2000	N/A
Voltage Dips and Interruption Immunity	EN 61326-1: 2006, EN 61326-2-2: 2006 Reference: IEC 61000-4-11:2004	N/A

Remark: 1. The symbol "N/A" in above table means Not Applicable.

2. When determining the test results, measurement uncertainty of tests has been considered.

2

EMC Results Conclusion
(with Justification)

RE: EMC Testing Pursuant to EMC Directive 2004/108/EC Performed On the MS2203: Three Phase Digital Power Clamp Meter, MS2205: Harmonic Power Clamp Meter ,
Models: MS2203, MS2205.

We tested the MS2203: Three Phase Digital Power Clamp Meter, MS2205: Harmonic Power Clamp Meter, Model: MS2203, MS2205, to determine if it was in compliance with the relevant EN standards as marked on the Test Results Summary. We found that the unit met the requirement of EN 61326-1: 2006(CISPR 11), EN 61326-1: 2006 (IEC 61000-4-2), EN 61326-1: 2006 (IEC 61000-4-3) standards when tested as received. The worst case's test data was presented in this test report. Test items Radiated Emission and Radiated Electromagnetic Field were subcontracted. The production units are required to conform to the initial sample as received when the units are placed on the market.

3

LABORATORY MEASUREMENTS**Configuration Information**

Equipment Under Test (EUT):	MS2203: Three Phase Digital Power Clamp Meter, MS2205: Harmonic Power Clamp Meter	
Model:	MS2203, MS2205	
Serial No.	Not Labelled	
Support Equipment:	N/A	
Rated Voltage:	DC 6V	
Condition of Environment:	Temperature	: 22~28°C
	Relative Humidity:	35~60%
	Atmosphere Pressure	86~106kPa

Notes:

1. The EMI measurements had been made in the operating mode producing the largest emission in the frequency band being investigated consistent with normal applications.

An attempt had be made to maximize the emission by varying the configuration of the EUT.

2. The EMS measurements had been made in the frequency bands being investigated, with the EUT in the most susceptible operating mode consistent with normal applications. The configuration of the test sample had been varied to achieve maximum susceptibility.

4 EMI TEST

4.1 Continuous Conducted Disturbance Voltage Test

Test Result: Not applicable

4.1.1 Used Test Equipment

Equipment No.	Equipment	Model	Manufacturer
EM080-05	EMI receiver	ESCI	R&S
EM006-05	LISN	ENV216	R&S
EM004-03	EMC shield Room	8m×4m×3m	Zhongyu

4.1.2 Block Diagram of Test Setup

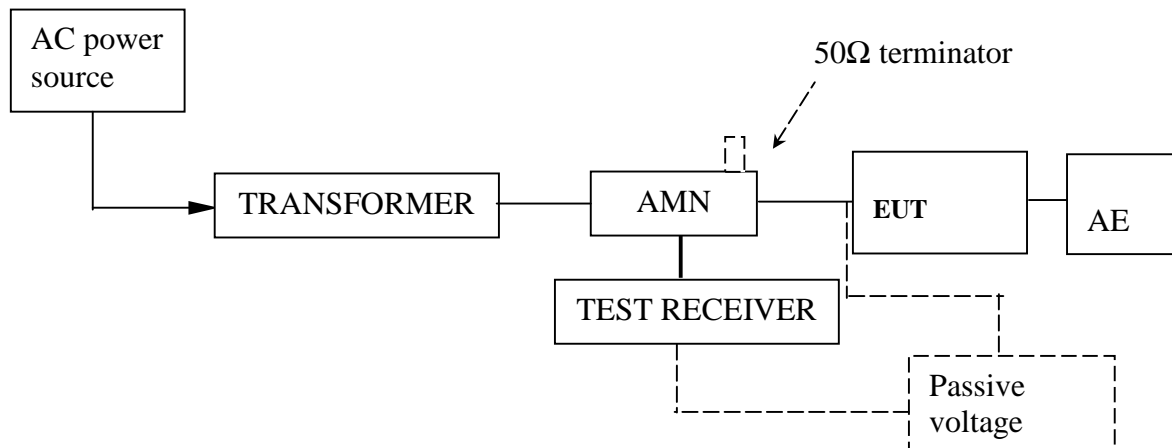

4.1.3 Test Setup and Procedure

The EUT was set to achieve the maximum emission level. The mains terminal disturbance voltage was measured with the EUT in a shielded room. The EUT was connected to AC power source through an Artificial Mains Network which provide a 50Ω linear impedance Artificial hand is used if appropriate (for handheld apparatus). The load/control terminal disturbance voltage was measured with passive voltage probe if appropriate.

The EUT was placed on a 0.8m high non-metallic table above a metallic plane, and 0.4m from wall of shielded room which is considered as Ground Reference Plane (GRP) (For floor standing EUT, was placed on a 0.1m high non-metallic supported on GRP) The EUT keeps a distance of at least 0.8m from any other of the metallic surface. The Artificial Mains Network is situated at a distance of 0.8m from the EUT.

During the test, mains lead of EUT excess 0.8m was folded back and forth parallel to the lead so as to form a horizontal bundle with a length between 0.3m and 0.4m.

The bandwidth of test receiver was set at 9kHz. The frequency range from 150kHz to 30MHz was checked.

4.1.4 Test Data

Not applicable

4.1.5 Emission Curve

Not applicable

4.1.6 Measurement Uncertainty

The measurement uncertainty describes the overall uncertainty of the given measured value during the operation of the EUT.

Measurement uncertainty is calculated in accordance with CISPR 16-4-2:2003.

Measurement uncertainty of mains terminal disturbance voltage in CISPR band A: 2.0dB.

Measurement uncertainty of mains terminal disturbance voltage in CISPR band B: 2.2dB.

The measurement uncertainty is given with a confidence of 95%, $k=2$.

4.2 Discontinuous Conducted Disturbance Voltage

Test Result: Not applicable

4.2.1 Used Test Equipment

Equipment No.	Equipment	Model	Manufacturer
EM008-01	Click Tester	DIA1512D	SCHAFFNER
EM006-06	LISN	ENV216	R&S
EM004-03	EMC shield Room	8m×4m×3m	Zhongyu

4.2.2 Block Diagram of Test Setup

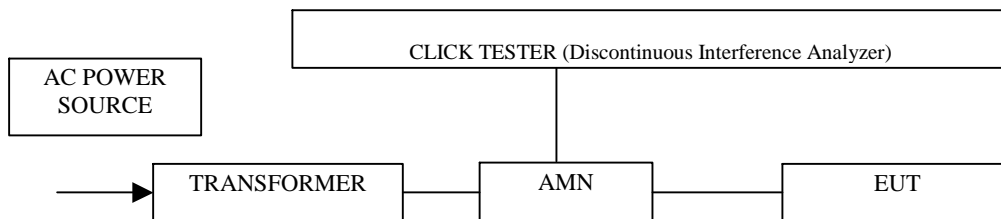

4.2.3 Test Setup and Procedure

The EUT was placed on a 0.8m high non-metallic table in shielded room, the wall of shielded room used as Ground Reference Plane (GRP), and keeps a distance of at least 0.8m from any of the other metallic surface.

The EUT was connected to an artificial mains network and at a distance of 0.8m from it, the excess lead of EUT was bundled with a length of 0.3m to 0.4m parallel to the main lead.

The number of counted clicks above the permitted limit for continuous interference and their duration, spacing and rate were measured during the observation time. When relevant, a permitted (relaxed) limit for clicks were calculated and a second measurement was performed. Determination of compliance with the permitted limit according to the upper quartile method was applied. The frequency 150kHz, 500kHz, 1.4MHz and 30MHz was checked.

4.2.4 Test Data

Not applicable

4.2.5 Measurement Uncertainty

The measurement uncertainty for click test is under consideration according to CISPR 16-4-2:2003.

4.3 Radiated Emission
Test Result: Pass

4.3.1 Used Test Equipment

Equip. No.	Equipment	Model	Manufacturer
SZ185-01	EMI receiver	ESCI	R&S
SZ061-03	Bilog Antenna	3142C	Chase
SZ188-01	Anechoic Chamber	RFD-F/A-100	ETS

4.3.2 Block Diagram of Test Setup

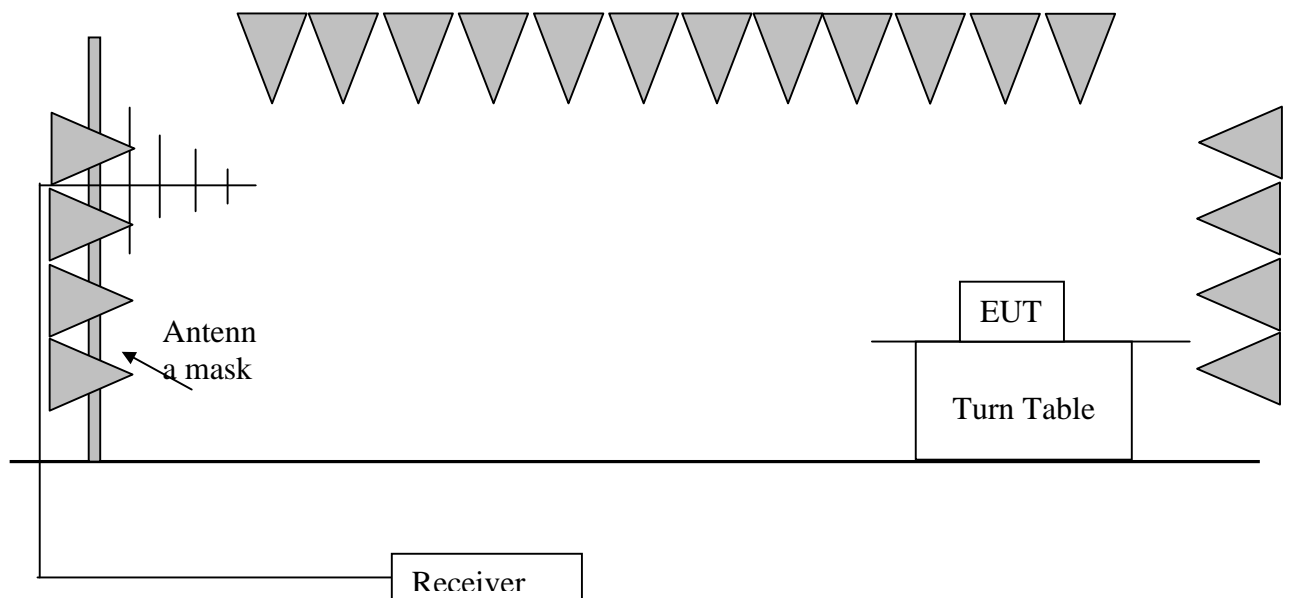

4.3.3 Test Setup and Procedure

The measurement was applied in a semi-anechoic chamber. The EUT and simulators were placed on a 0.8m high wooden turntable above the horizontal metal ground plane. The turn table rotated 360 degrees to determine the position of the maximum emission level. The EUT was set 3 meters away from the receiving antenna which was mounted on an antenna mask. The antenna moved up and down between from 1 meter to 4 meters to find out the maximum emission level.

Broadband antenna was used as receiving antenna. Both horizontal and vertical polarization of the antenna was set on measurement. In order to find the maximum emission, all of the interface cables were manipulated according to CISPR11 requirement during radiated test. The bandwidth setting on R&S Test Receiver was 120 kHz.

The frequency range from 30MHz to 1000MHz was checked

4.3.4 Test Data**Model: MS2203****Operation mode: Measure Voltage**

Antenna Polarization	Frequency [MHz]	Measured Net at 3m [dB(μV/m)]	Limit at 3m [dB(μV/m)]
Horizontal	200.0	<30	40.0
Horizontal	104.3	28.4	40.0
Horizontal	400.0	<30	47.0
Horizontal	800.0	<30	47.0
Vertical	33.2	39.3	40.0
Vertical	200.0	<30	40.0
Vertical	400.0	<35	47.0
Vertical	800.0	<35	47.0

Model: MS2203**Operation mode: Measure Power**

Antenna Polarization	Frequency [MHz]	Measured Net at 3m [dB(μV/m)]	Limit at 3m [dB(μV/m)]
Horizontal	200.0	<30	40.0
Horizontal	400.0	<30	47.0
Horizontal	800.0	<30	47.0
Vertical	39.0	35.2	40.0
Vertical	44.2	33.6	40.0
Vertical	200.0	<30	40.0
Vertical	400.0	<35	47.0
Vertical	800.0	<35	47.0

Model: MS2205

Operation mode: Measure Voltage

Antenna Polarization	Frequency [MHz]	Measured Net at 3m [dB(μV/m)]	Limit at 3m [dB(μV/m)]
Horizontal	200.0	<30	40.0
Horizontal	400.0	<30	47.0
Horizontal	800.0	<30	47.0
Vertical	114.0	26.1	40.0
Vertical	200.0	<30	40.0
Vertical	400.0	<35	47.0
Vertical	800.0	<35	47.0

Model: MS2205

Operation mode: Measure Power

Antenna Polarization	Frequency [MHz]	Measured Net at 3m [dB(μV/m)]	Limit at 3m [dB(μV/m)]
Horizontal	200.0	<30	40.0
Horizontal	400.0	<30	47.0
Horizontal	800.0	<30	47.0
Vertical	112.5	24.3	40.0
Vertical	200.0	<30	40.0
Vertical	400.0	<35	47.0
Vertical	800.0	<35	47.0

4.3.5 Test Curve

Model: MS2203

Operation mode: Measure Voltage

H

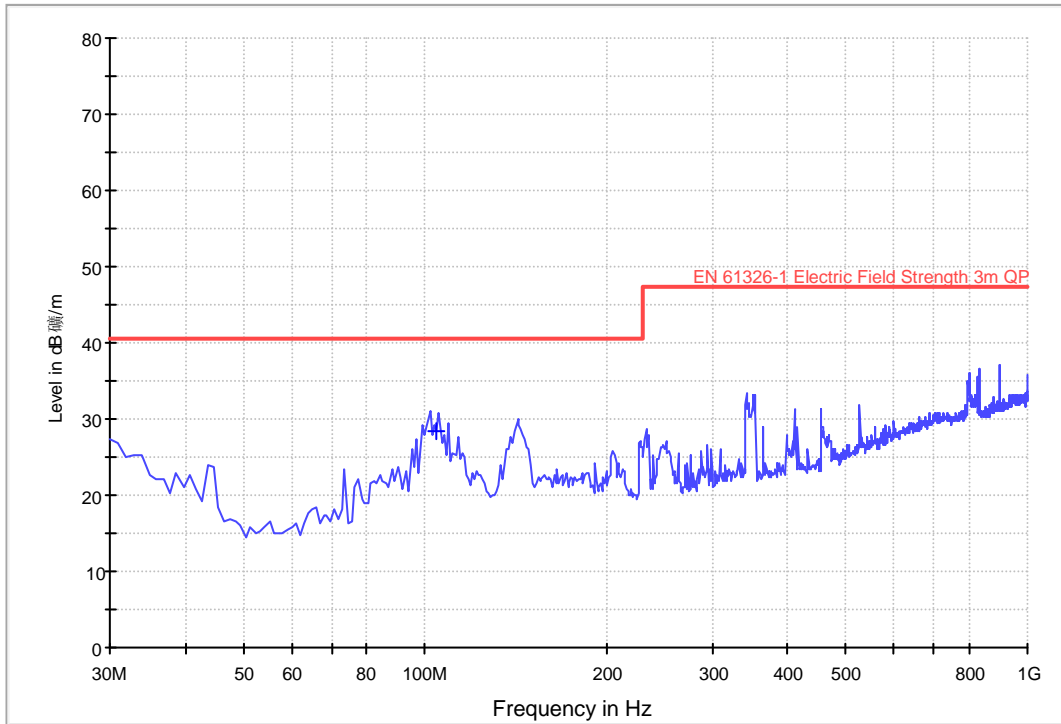

V

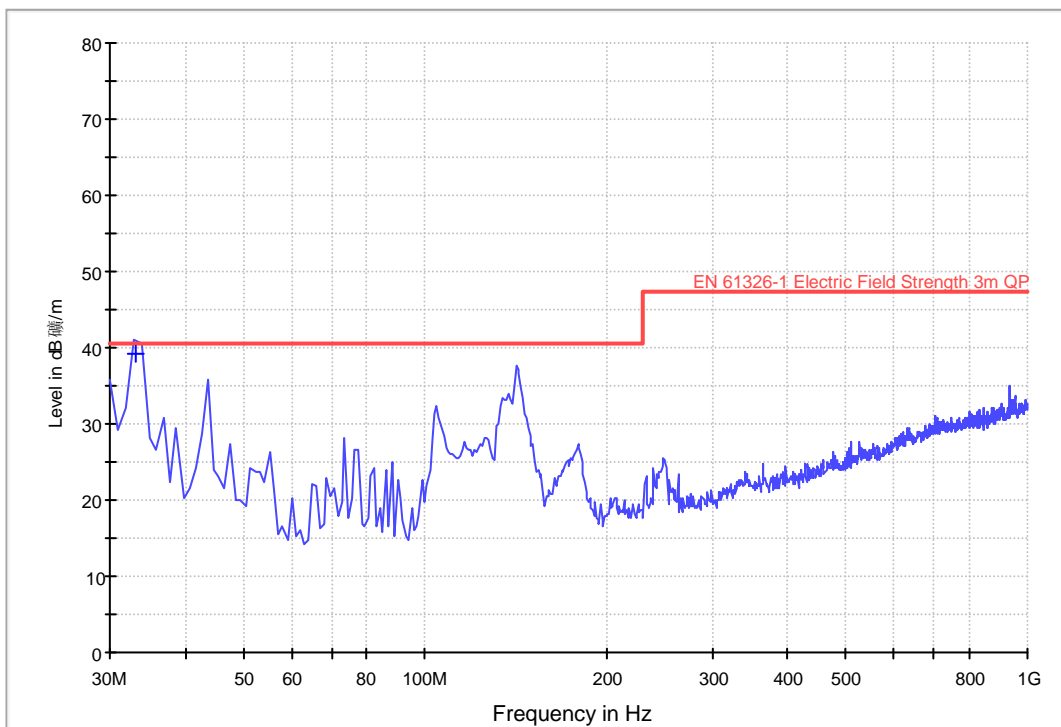

Model: MS2203

Operation mode: Measure Power

H

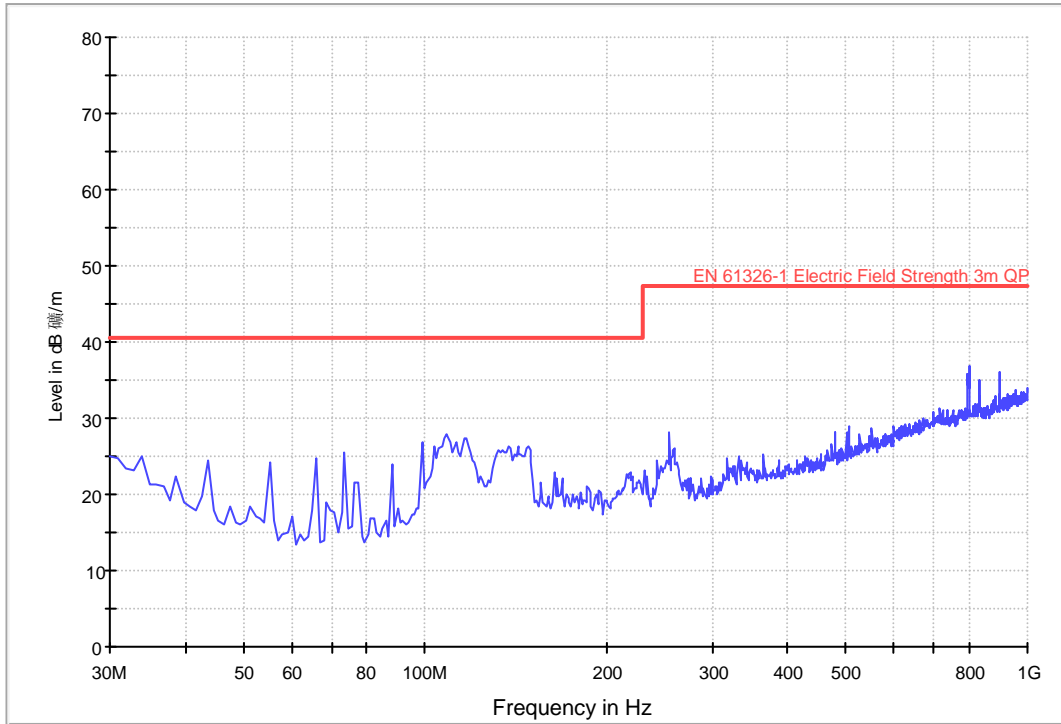

V

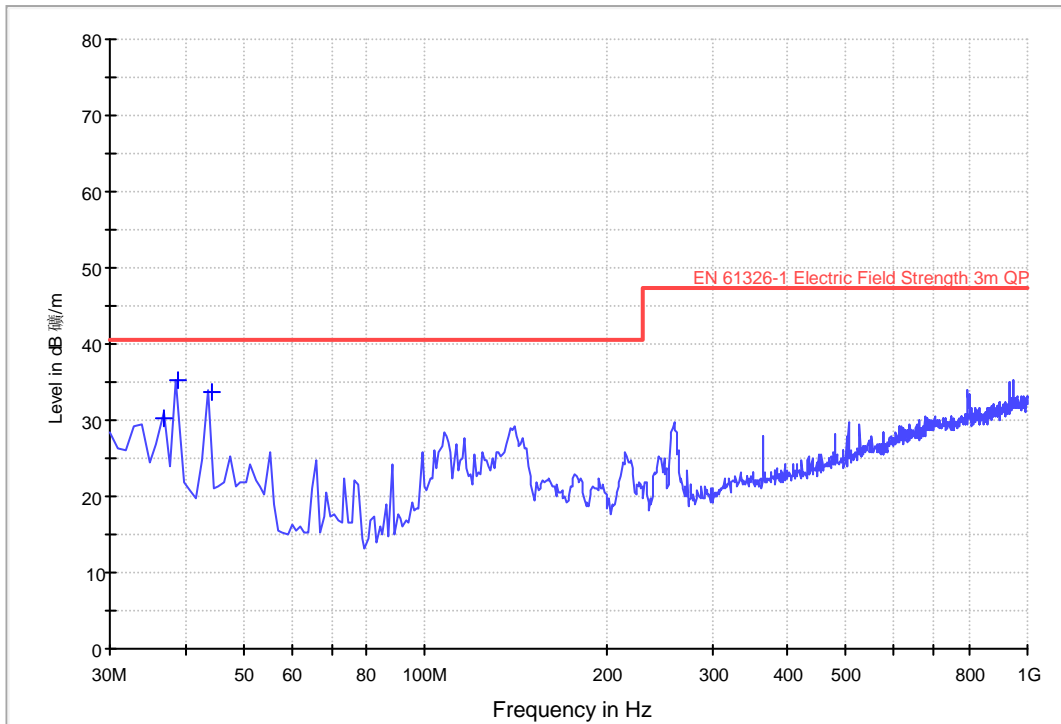

Model: MS2205
H

Operation mode: Measure Voltage

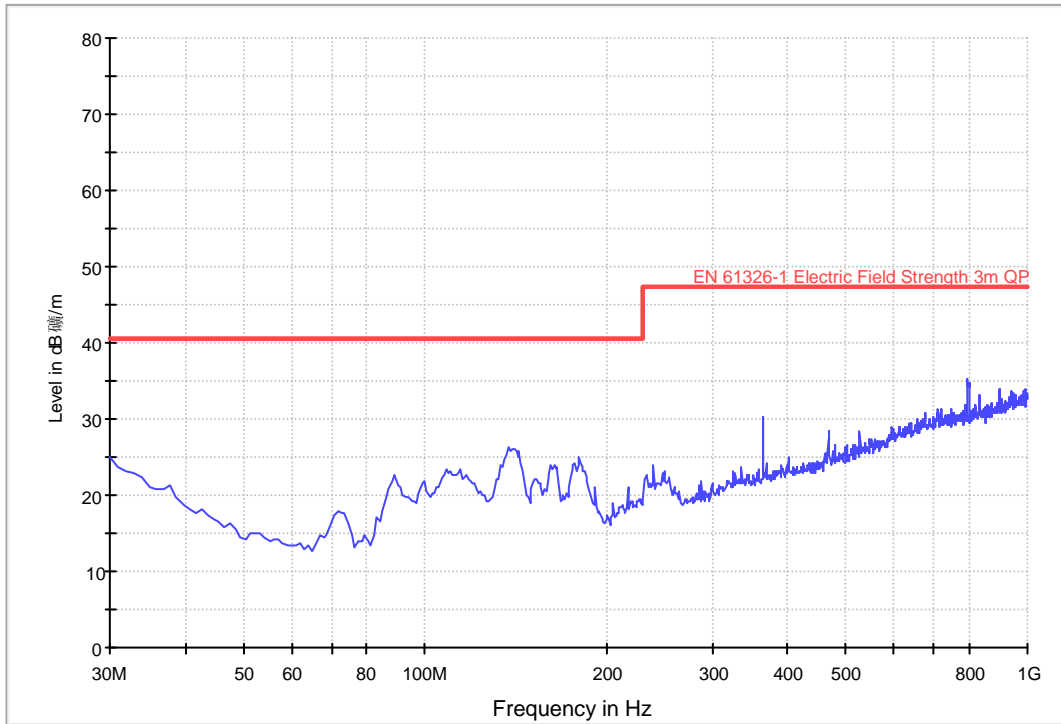

V

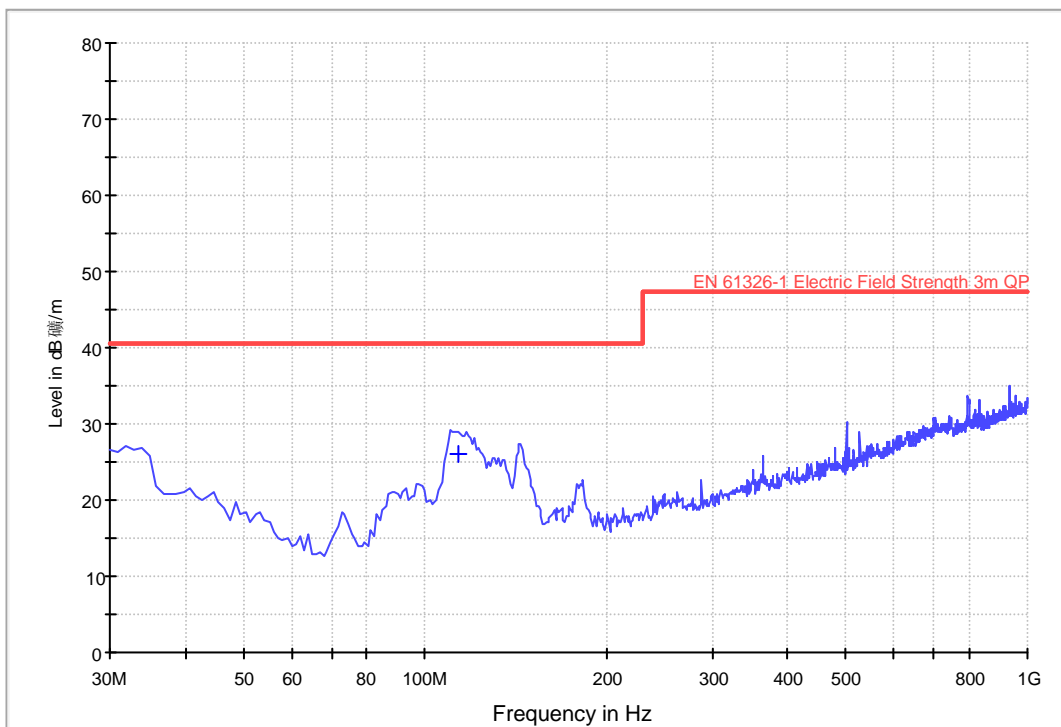

Model: MS2205

Operation mode: Measure Power

H

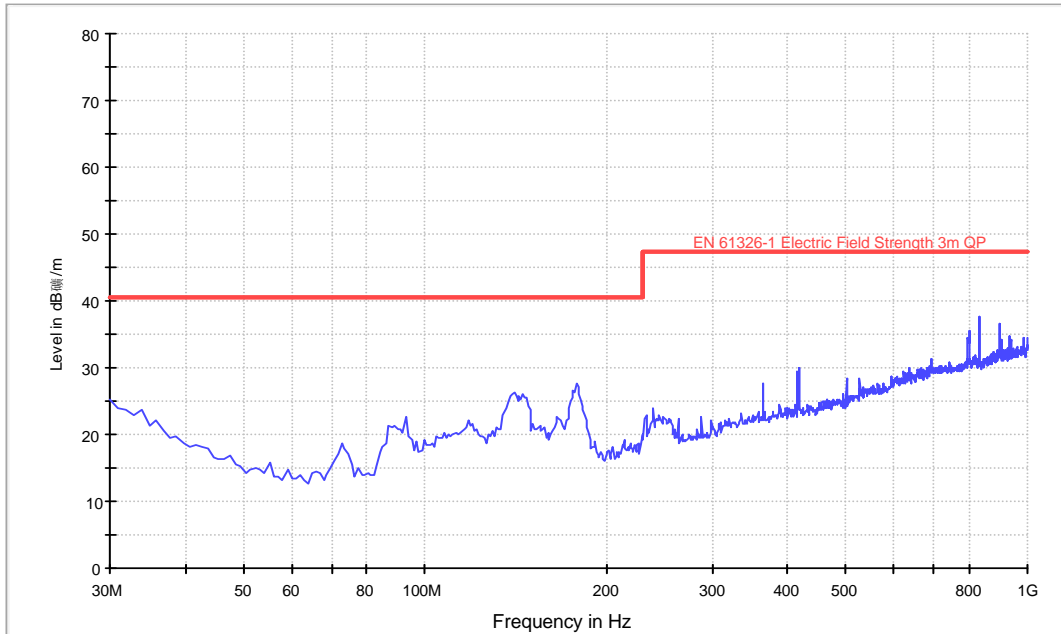

V

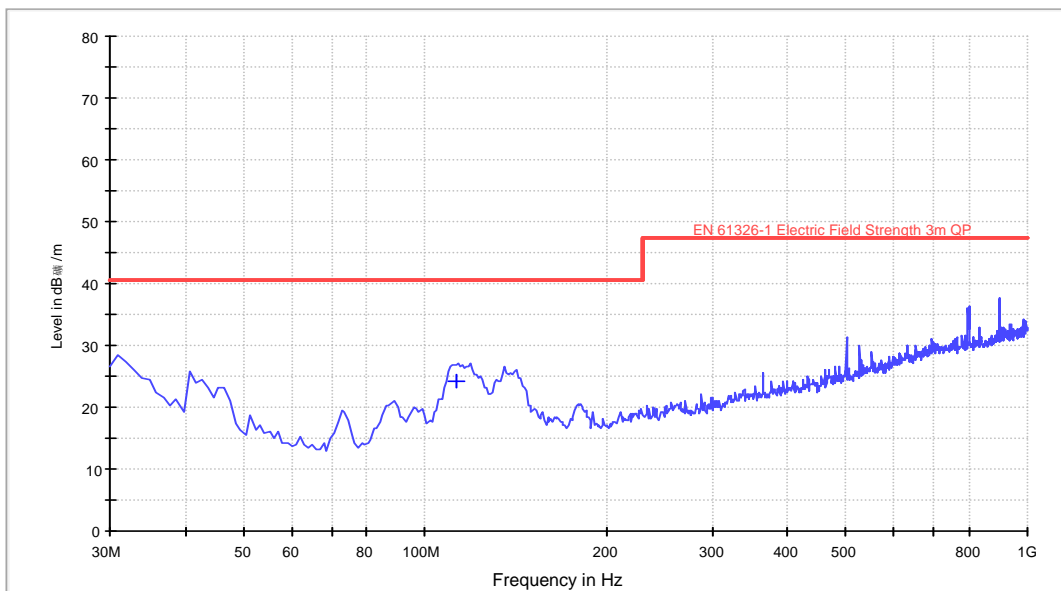

4.3.6 Measurement uncertainty

The measurement uncertainty describes the overall uncertainty of the given measured value during the operation of the EUT.

Measurement uncertainty is calculated in accordance with CISPR 16-4-2:2003.

Measurement uncertainty of radiated emission: 4.8 dB.

The measurement uncertainty is given with a confidence of 95%, $k=2$.

5 Harmonic of Current

Test Result: Not applicable

5.1 Used Test Equipment

Equip. No.	Equipment	Model	Manufacturer
EM001-01	Harmonic & Flicker Test System	CTS 3.0	California Instrument

5.2 Block Diagram of Test Setup

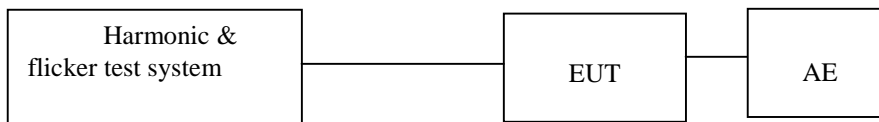

5.3 Test Setup and Procedure

Harmonics of the fundamental current were measured up to 40 order harmonics using a digital power meter with an analogue output and frequency analyser which was integrated in the harmonic & flicker test system. The measurements were carried out under steady conditions.

□ This product is not defined as lighting equipment, and has rated power less than 75W, therefore, no limit apply according to IEC 61000-3-2.

5.4 Test Data

Not applicalbe

5.5 Measurement Uncertainty

The measurement uncertainty for harmonic test is under consideration according to CISPR 16-4-2:2003.

6 Flicker

Test Result: Not applicable

6.1 Used Test Equipment

Equip. No.	Equipment	Model	Manufacturer
EM001-01	Harmonic & Flicker Test System	CTS 3.0	California Instrument

6.2 Block Diagram of Test Setup

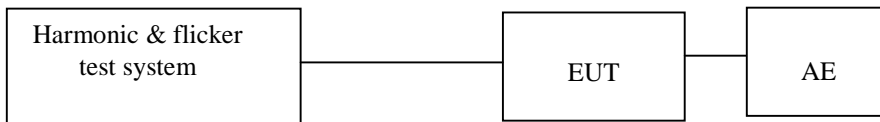

6.3 Test Setup and Procedure

6.3.1 Definition

- Flicker: impression of unsteadiness of visual sensation induced by a lighting stimulus whose luminance or spectral distribution fluctuates with time.
- Pst: Short-term flicker indicator The flicker severity evaluated over a short period (in minutes); Pst=1 is the conventional threshold of irritability
- Plt: long-term flicker indicator; the flicker severity evaluated over a long period (a few hours). Using successive Pst value.
- dc: the relative steady-state voltage change
- dmax: the maximum relative voltage change
- d(t): the value during a voltage change

6.3.2 Test condition

The EUT was set to produce the most unfavourable sequence of voltage changes.

6.4 Test Data

Not applicable

6.5 Measurement Uncertainty

Measurement uncertainty for voltage fluctuation and flicker is under consideration according to CISPR 16-4-2:2003.

7 EMS TEST

Performance Criteria:

- Criterion A: The apparatus shall continue to operate as intended during the test. No degradation of performance or loss of function is allowed below a performance level (or permission loss of performance) specified by the manufacturer, when the apparatus is used as intended. If the minimum performance level or the permissible performance loss is not specified by the manufacturer, then either of these may be derived from the product description and documentation and from what the user may reasonably expect from the apparatus if used as intended.
- Criterion B: The apparatus shall continue to operate as intended after the test. No degradation of performance or loss of function is allowed below a performance level (or permission loss of performance) specified by the manufacturer, when the apparatus is used as intended. During the test, degradation of performance is allowed, however, no change of actual operating state or stored data is allowed. If the minimum performance level or the permissible performance loss is not specified by the manufacturer, then either of these may be derived from the product description, and documentation, and from what the user may reasonably expect from the apparatus if used as intended.
- Criterion C: Temporary loss of function is allowed, provided the function is self-recoverable or can be restored by the operation of the controls, or by any operation specified in the instruction for use.

Measurement Uncertainty

According to CISPR 16-4-2:2003, measurement uncertainty to immunity test is under consideration.

7.1 IEC 61000-4-2(Pursuant to EN 61326) Electrostatic Discharge Immunity

Tested Port: Enclosure

Performance criterion: B

Test Result: Pass

7.1.1 Used Test Equipment

Equip. No.	Equipment	Model	Manufacturer
EM077-03	ESD Simulator	KES4021	KIKUSUI

7.1.2 Block Diagram of Test Setup

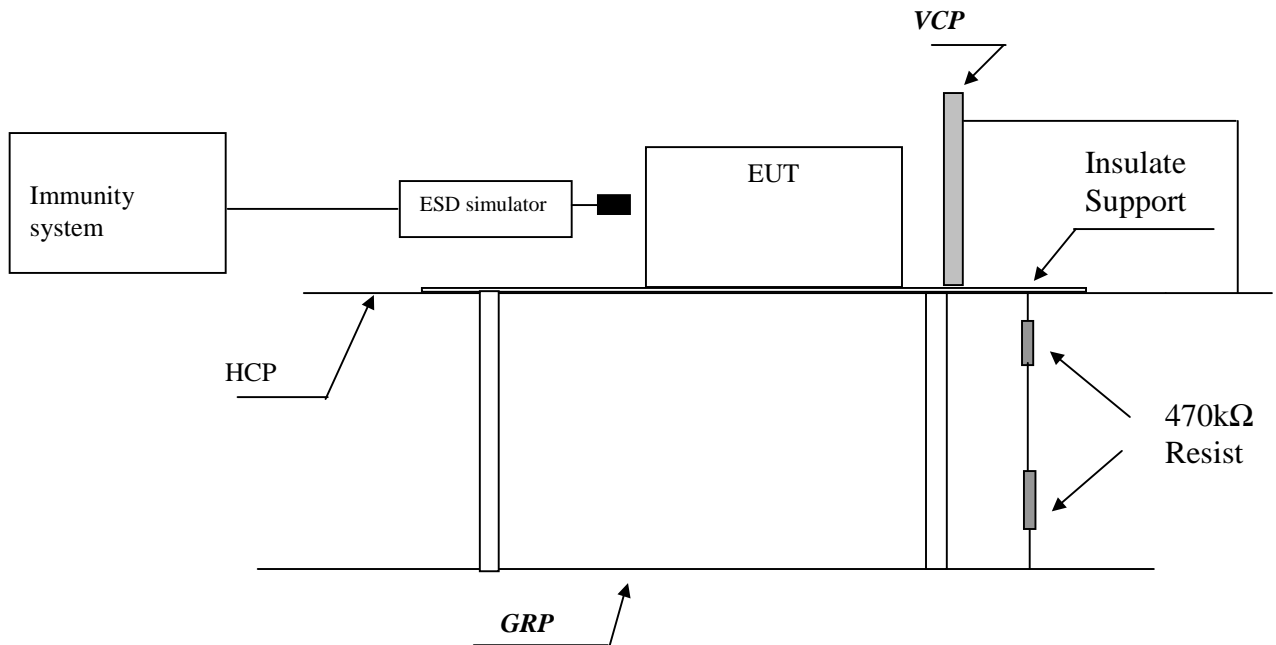

Note: HCP means Horizontal Coupling Plane,
 VCP means Vertical Coupling Plane
 GRP means Ground Reference Plane

7.1.3 Test Setup and Procedure

The EUT was put on a 0.8m high wooden table/0.1m high for floor standing equipment standing on the ground reference plane (GRP) 3m by 2m in size, made by iron 1.0 mm thick.

A horizontal coupling plane (HCP) 1.6m by 0.8m in size was placed on the table, and the EUT with its cables were isolated from the HCP by an insulating support thick than 0.5mm. The VCP 0.5m by 0.5m in size & HCP were constructed from the same material type & thickness as that of the GRP, and connected to the GRP via a 470kΩ resistor at each end.

The distance between EUT and any of the other metallic surface excepted the GRP, HCP & VCP was greater than 1m.

The EUT was arranged and connected according to its functional requirements.
 The EUT was arranged and connected according to its functional requirements

Direct static electricity discharges was applied only to those points and surface which are accessible to personnel during normal usage.

Test voltage was increased from the minimum to the selected test level and with single discharge.

On each preselected points 10 times of each polarity single discharge were applied The time interval between successive single discharges is 1s.

The ESD generator was held perpendicular to the surface to which the discharge is applied. The discharge return cable of the generator was kept at a distance of 0.2m whilst the discharge is being applied. During the contact discharges, the tip of the discharge electrode was touch the EUT before the discharge switch is operated. During the air discharges, the round discharge tip of the discharge electrode was approached as fast as possible to touch the EUT.

Indirect discharge was conducted to objects placed near the EUT, simulated by applying the discharges of the ESD generator to a coupling plane, in the contact discharge mode.

After each discharge, the ESD generator was removed from the EUT, the generator is then retriggered for a new single discharge. For ungrounded product, a carbon fibre brush bleeder resistors in the ground cable were used after each discharge.

10 times of each polarity single discharge were applied to HCP and VCP. The detail selected points are listed in the following table.

7.1.4 Test Result**Direct Application of ESD**

Direct Contact Discharge

Applied Voltage (kV)	No. of Discharge for each point	Result	Discharged Points
4	20	N/A	all touchable screws of enclosure, accessible metal parts of the EUT

Direct Air Discharge

Applied Voltage (kV)	No. of Discharge for each point	Result	Discharged Points
8	20	Pass	Air gap of the switch, button, the air in-taking opening, slots around the EUT

Indirect Application of ESD

Horizontal Coupling Plane under the EUT

Applied Voltage (kV)	No. of Discharge for each point	Result	Discharged Point
4	20	Pass	Edge of centre, corner on HCP

Vertical Coupling Plane beside the EUT

Applied Voltage (kV)	No. of Discharge for each point	Result	Discharged Point
4	20	Pass	Edge of centre, corner on VCP

7.2 IEC 61000-4-6(Pursuant to EN 61326) Injected Current (0.15 MHz to 80 MHz)

Tested Port: AC power DC power Functional earth Signal/Control

Performance criterion: A

Test Result: Not applicable

7.2.1 Used Test Equipment

Equip. No.	Equipment	Model	Manufacturer
EM003-01	Conducted Disturbance Generator	CDG_1020	Dr.Hubert GmbH

7.2.2 Block Diagram of Test Setup

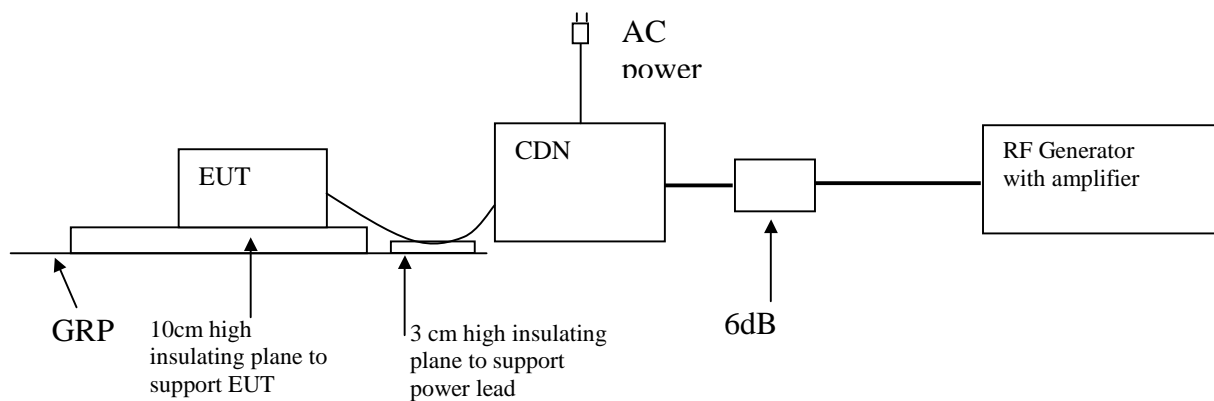

7.2.3 Test Setup and Procedure

The EUT was placed on an insulating support of 0.1m height above a ground reference Plane, arranged and connected to satisfy its functional requirement.

All relevant cables were provided with the appropriate coupling and decoupling devices at a distance between 0.1m and 0.3m from the projected geometry of the EUT on an insulating support of 0.03m height above the ground reference plane.

Test voltage was verified before each testing though power meter combined in the RF generator with AMP.

Dwell time was set to 3s and step was set as 1% to keep sufficient response time for EUT.

The frequency from 0.15MHz to 230MHz was checked.

7.2.4 Test Result

Port:	Frequency (MHz)	Level	Result
A.C. Power Lines	0.15 to 80	3V (r.m.s.)	N/A
D.C. Power Lines	0.15 to 80	3V (r.m.s.)	N/A
Signal Lines	0.15 to 80	3V (r.m.s.)	N/A
Control Lines	0.15 to 80	3V (r.m.s.)	N/A
Functional Earth	0.15 to 80	3V (r.m.s.)	N/A

7.3 IEC 61000-4-4(Pursuant to EN 61326) Electrical Fast Transient/Burst

Tested Port: AC power DC power Functional earth Signal/Control
Performance criterion: B
Test Result: Not applicable

7.3.1 Used Test Equipment

Equip. No.	Equipment	Model	Manufacturer
EM005-07	EMS test system	Ecompact 4	HAEFELY
EM074-01	EMS test system	Best EMC	SCHAFFNER

7.3.2 Block Diagram of Test Setup

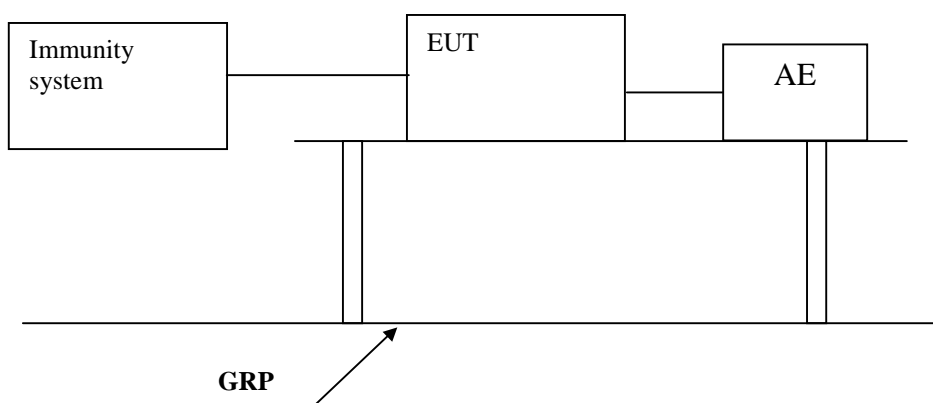

7.3.3 Test Setup and Procedure

The EUT was placed on a 0.1m high wooden table, standing on the ground reference plane 3m by 2m in size, made by steel 1mm thick.

The distance between the EUT and any other of the metallic surface except the GRP is greater than 0.5m.

The mains lead excess than 0.5m is folded to a flat coil and situated at a distance of 0.1m above the ground reference plane to insure the distance between the coupling device and the EUT were 0.5m.

The EUT was arranged and connected to satisfy its functional requirement and supplied by the coupling-decoupling network.

7.3.4 Test Result

Level	Polarity	A.C. Power supply line and functional earth terminal	D.C. Power Lines, Signal Line & Control Line
0.5kV	+	N/A	N/A
0.5kV	-	N/A	N/A
1kV	+	N/A	N/A
1kV	-	N/A	N/A

7.4 IEC 61000-4-5(Pursuant to EN 61326) Surge Immunity

Tested Port: AC power DC power
Performance criterion: B
Test Result: Not applicable

7.4.1 Used Test Equipment

Equip. No.	Equipment	Model	Manufacturer
EM005-07	EMS test system	Ecompact 4	HAEFELY
EM005-08	Surge Generator	NSG2050	SCHAFFNER

7.4.2 Block Diagram of Test Setup

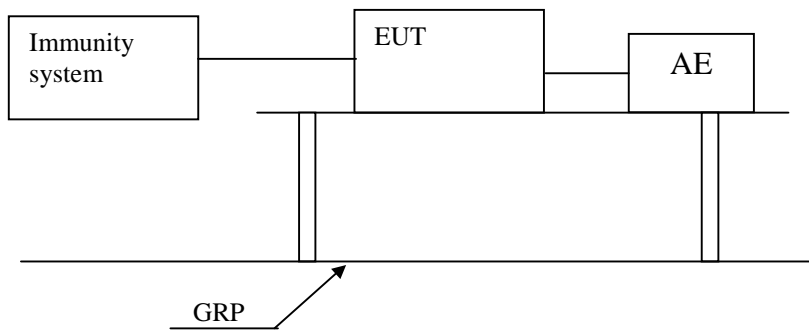

7.4.3 Test Setup and Procedure

The surge is to be applied to the EUT power supply terminals via the capacitive coupling network.

Decoupling networks are required in order to avoid possible adverse effects on equipment not under test that may be powered by the same lines and to provide sufficient decoupling impedance to the surge wave so that the specified wave may be developed on the lines under test.

The EUT was arranged and connected according to its functional requirements. The EUT was placed on a 0.8m high wooden table, standing on a ground reference plane 3m by 2m in size (for floor standing EUT, was placed on a 0.1m high wooden support above the GRP), supplied by the coupling-decoupling network, and arranged and connected to satisfy its functional requirement and the power code between the EUT and the coupling/decoupling network was less than 2 meters.

Surge is applied to the EUT power supply terminals.

7.4.4 Test Result

Tested Port	Level	Result
AC power	Line to line $\pm 1\text{kV}$	N/A
AC power	Line to earth $\pm 2\text{kV}$	N/A
DC power	Line to line $\pm 0.5\text{kV}$	N/A
DC power	Line to earth $\pm 0.5\text{kV}$	N/A

7.5 IEC 61000-4-11(Pursuant to EN 61326) Voltage Dips and Interruptions

Tested Port: AC power

Performance criterion: B (only for test level of 70%Ut with 0.5 cycle), C

Test Result: Not applicable

7.5.1 Used Test Equipment

Equip. No.	Equipment	Model	Manufacturer
EM005-07	EMS test system	Ecompact 4	HAEFELY
EM074-01	EMS test system	Best EMC	SCHAFFNER

7.5.2 Block Diagram of Test Setup

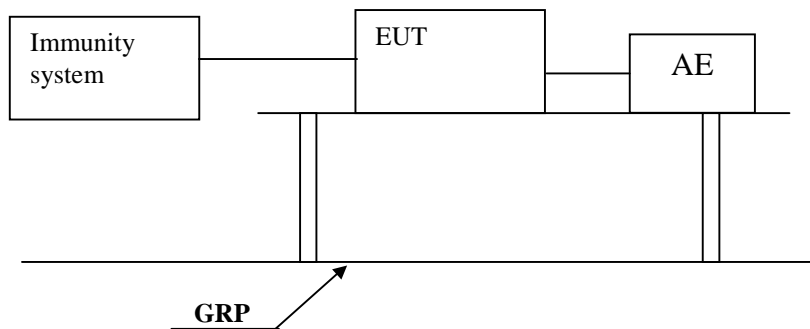

7.5.3 Test Setup and Procedure

The EUT was placed on an insulating support of 0.8m height, standing on a ground reference plane, and arranged and connected to satisfy its functional requirement

The test was performed with the EUT connected to the test generator with the shortest power supply cable as specified by the EUT manufacturer.

The EUT was tested for each selected combination of test level and duration with a sequence of three dips/interruptions with intervals of 10 s minimum. Each representative mode of operation was tested.

EUT is tested for voltage dips of 100% U_T , 250 period, 40% U_T , 5 periods and 70% U_T , 0.5 periods, for 100% U_T , both the positive and negative polarity test was conducted.

Abrupt changes in supply voltage was occur at zero crossings of the voltage.

7.5.4 Test Result

Test condition			Result
Test Level in % U_T	Duration (in period of the rated frequency)		
Voltage dip	0	0.5	N/A
	0	1	N/A
	70	25	N/A
Short interruptions	0	250	N/A

Remark: U_T is the rated voltage for the equipment.

7.6 IEC 61000-4-3(Pursuant to EN 61326) Radiated Electromagnetic Field Immunity

Tested Port: Enclosure

Performance criterion: A

Test Result: Pass

7.6.1 Used Test Equipment

Equip. No.	Equipment	Model	Manufacturer
SZ180-01	Signal Generator	SML03	R&S
SZ186-01	Voltage Probe	HI-6105	ETS
SZ181-01	Power Amplifier	AP32 MT215	PRANA
SZ181-02	Power Amplifier	AS0825-35	MILMEGA
SZ061-04	Bilog Antenna	3142C	ETS
SZ182-01	Power Meter	4232A	BOONTON
SZ188-02	Anechoic Chamber	RFD-F/A-100	ETS

7.6.2 Block Diagram of Test Setup

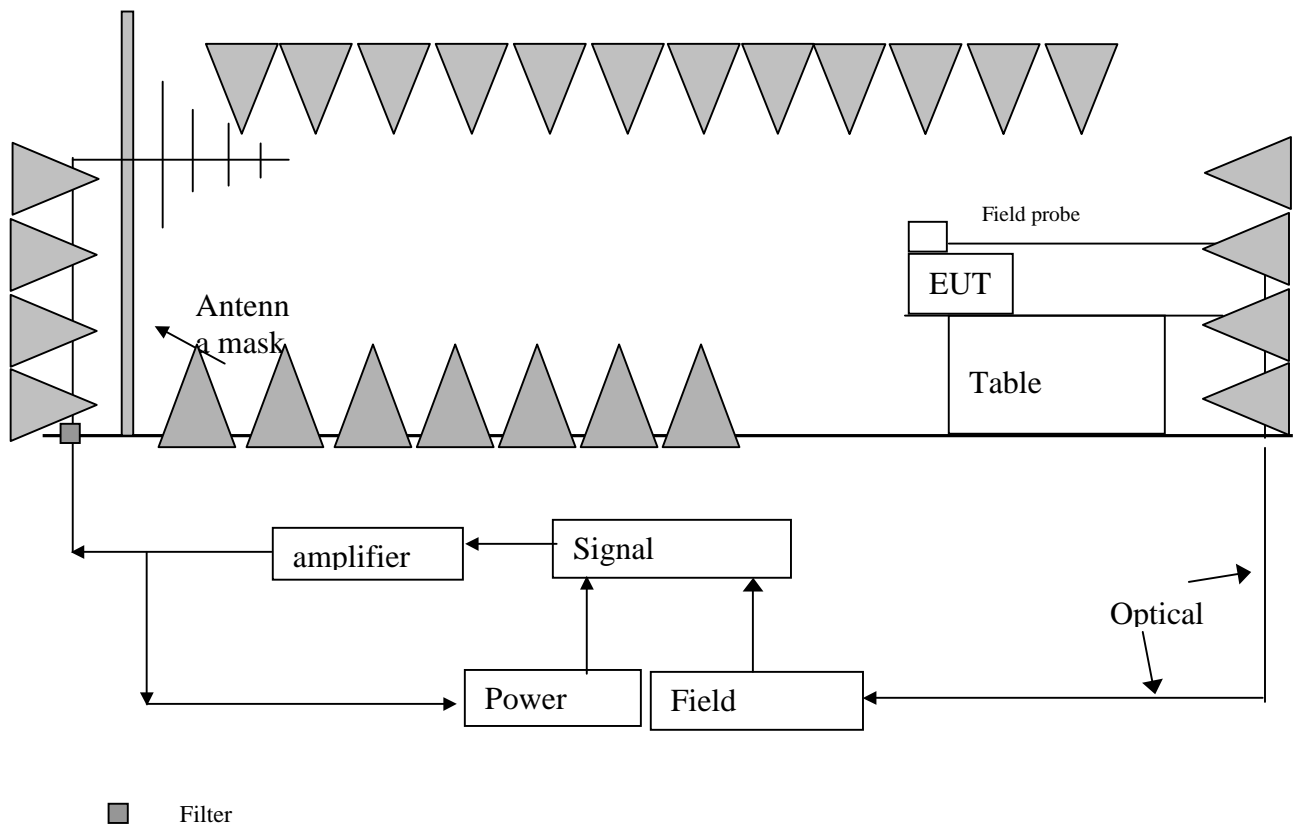

7.6.3 Test Setup and Procedure

The test was conducted in a fully anechoic chamber to maintain a uniform field of sufficient dimensions with respect to the EUT, and also in order to comply with various national and international laws prohibiting interference to radio communications.

The equipment is placed in the test facility on a non-conducting table 0.8m high (for floor standing EUT, is placed on a non-conducting support 0.1m height).

For all ports connected to EUT, manufacturer specified cable type and length was used, for those cables no specification, unshielded cable applied.

Wire is left exposed to the electromagnetic field for a distance of 1m from the EUT.

The EUT was arranged and connected according to its functional requirements

Before testing, the intensity of the established field strength have been checked by placing the field sensor at a calibration grid point, and with the field generating antenna and cables in the same positions as used for the calibration, the forward power needed to give the calibrated field strength was measured.

After calibration, the EUT is initially placed with one face coincident with the calibration plane.

The frequency range is swept from 80MHz to 1000MHz at 3V/m EM field, 1.4 GHz to 2 GHz at 3V/m EM field and 2.0 GHz to 2.7 GHz at 1V/m EM field, with the signal 80% amplitude modulated with a 1 kHz sine-wave, pausing to adjust the r.f. signal level.

The dwell time at each frequency was 3s so as that the EUT to be exercised and be able to respond.

The step size was 1% of the fundamental with linear interpolation between calibrated points. Test was performed with the generating antenna facing each of the four sides of the EUT.

7.6.4 Test Result

Frequency (MHz)	Exposed Side	Field Strength (V/m)	Result
80 to 1000	Front	3V/m (r.m.s.)	Pass
80 to 1000	Left	3V/m (r.m.s.)	Pass
80 to 1000	Rear	3V/m (r.m.s.)	Pass
80 to 1000	Right	3V/m (r.m.s.)	Pass

Frequency (GHz)	Exposed Side	Field Strength (V/m)	Result
1.4 to 2.0	Front	3V/m (r.m.s.)	Pass
1.4 to 2.0	Left	3V/m (r.m.s.)	Pass
1.4 to 2.0	Rear	3V/m (r.m.s.)	Pass
1.4 to 2.0	Right	3V/m (r.m.s.)	Pass

Frequency (GHz)	Exposed Side	Field Strength (V/m)	Result
2.0 to 2.7	Front	1V/m (r.m.s.)	Pass
2.0 to 2.7	Left	1V/m (r.m.s.)	Pass
2.0 to 2.7	Rear	1V/m (r.m.s.)	Pass
2.0 to 2.7	Right	1V/m (r.m.s.)	Pass

7.7 IEC 61000-4-8(Pursuant to EN 61326) Power Frequency Magnetic Field Immunity

Tested Port: Enclosure

Performance criterion: A

Test Result: Not Applicable

7.7.1 Used Test Equipment

Equipment No.	Equipment	Model	Manufacturer
SB2617	EMCPRO	EMCPro	KEYTEK
SB2617/01	COIL	F-1000-4-8	KEYTEK

7.7.2 Block Diagram of Test Setup

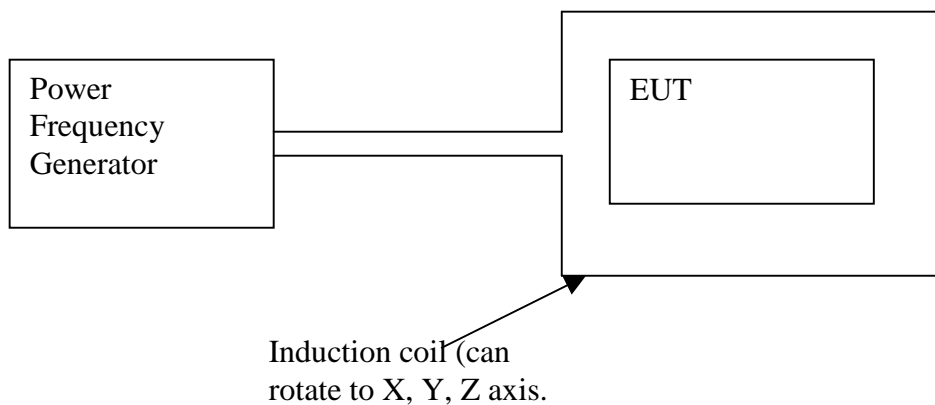

7.7.3 Test Setup and Procedure

Put EUT into center of induction coil(with suitable dimensions) in the testing.

For tabletop equipment:

The EUT was placed on a big enough wooden desk with height of 0.8m and operating as intended.

The equipment shall be subjected to the test magnetic field by using the induction coil of standards(1m*1m).

The induction coil shall be rotated by 90° in order to expose the EUT to the test field with different orientations.

For Floor-standing equipment:

The EUT was placed on big enough wooden desk with height of 0.1m and operating as intended.

The equipment shall be subjected to the test magnetic field by using induction coils of suitable dimensions; the test shall be repeated by moving and shifting the induction coils, in order to test the whole volume of the EUT for each orthogonal direction. The test shall be repeated with the coil shifted to different position along the side of the EUT, in steps corresponding to 50% of the shortest side of the coil.

The induction coil shall then be rotated by 90° in order to expose the EUT to the test field with different orientations and the same procedure followed.

7.7.4 Test Result

Mains frequency: **50Hz**

60Hz

Orientations of induction coil	Magnetic Field Strength (A/m)	Result
X	3A/m	N/A
Y	3A/m	N/A
Z	3A/m	N/A

8 Appendix I - Photos of test setup

Radiated Emission

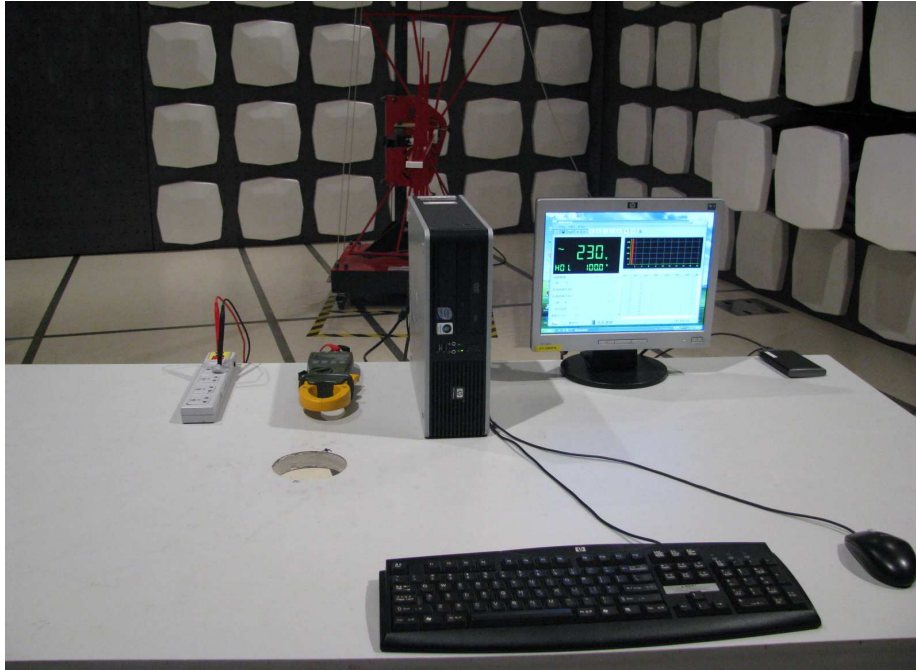

ESD Immunity



Radiated Electromagnetic Field

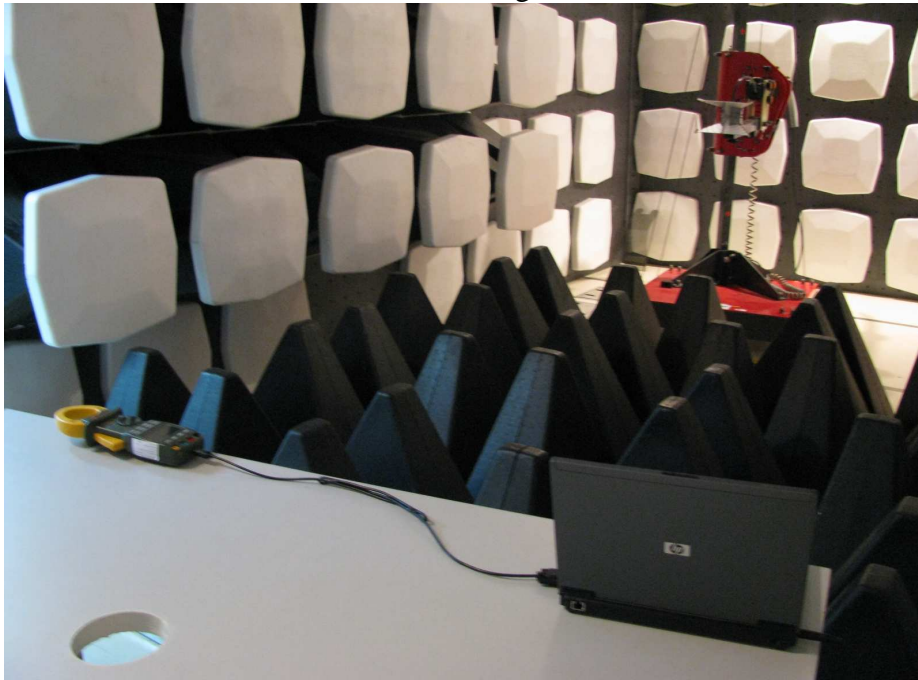

9 Appendix II - Photos of EUT

Inside
MS2205

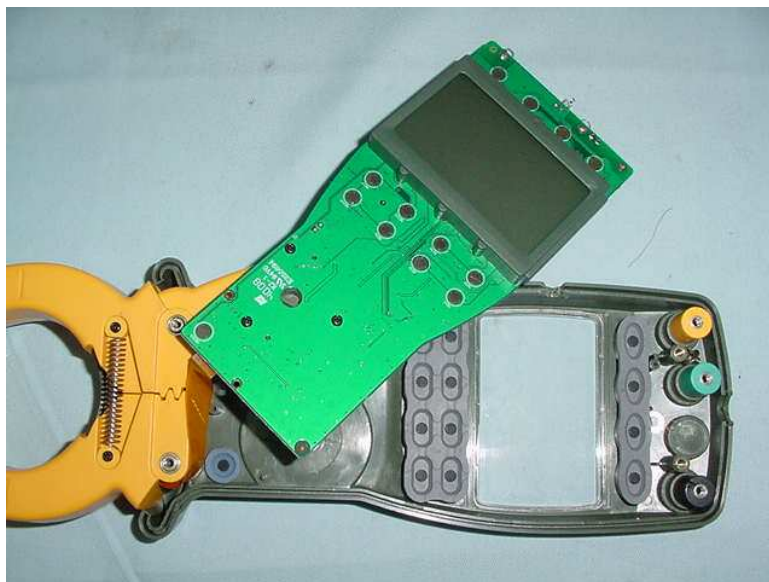

MS2203

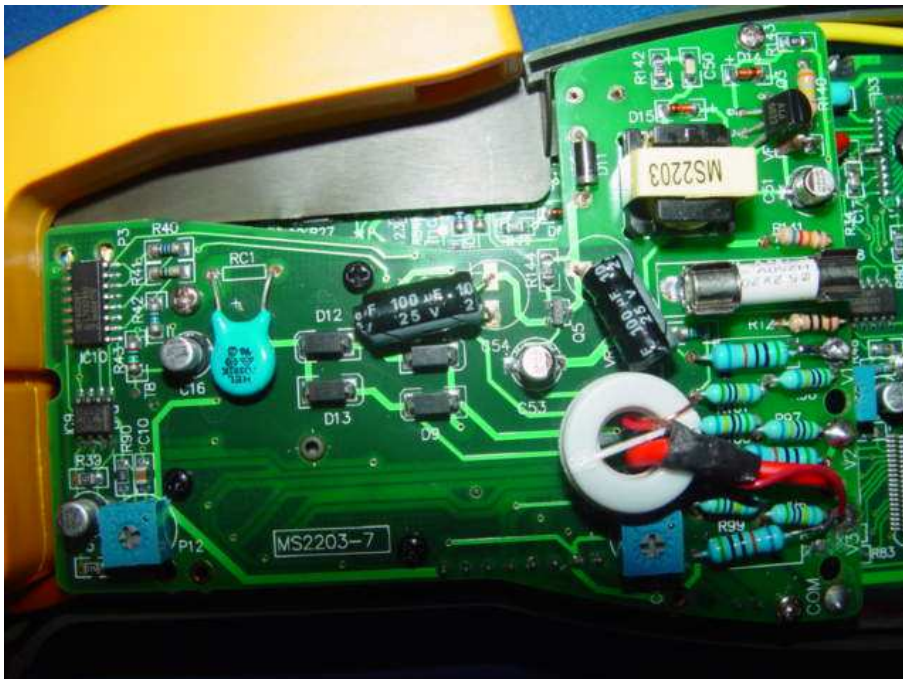
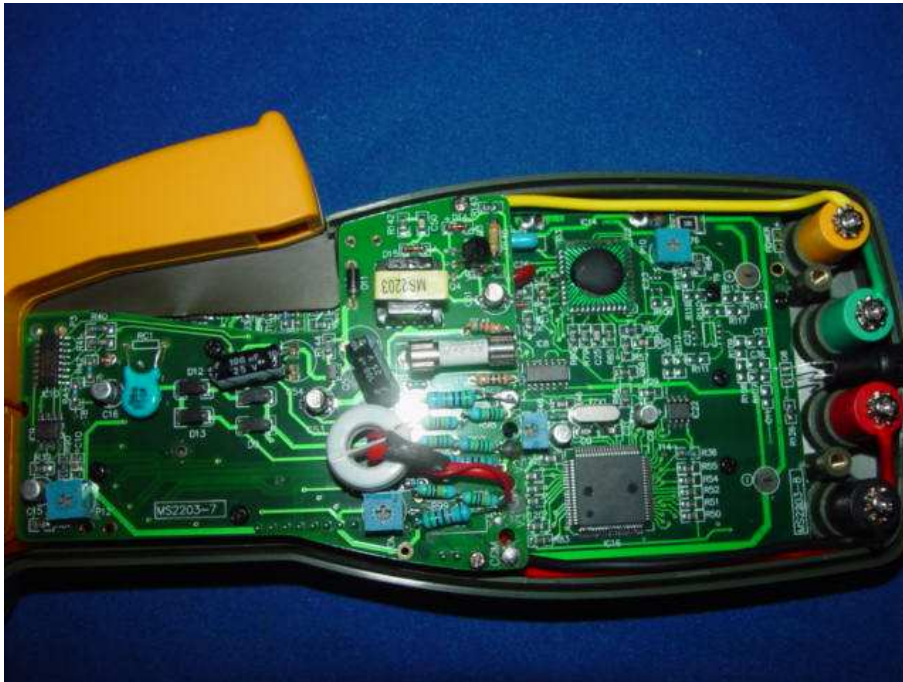

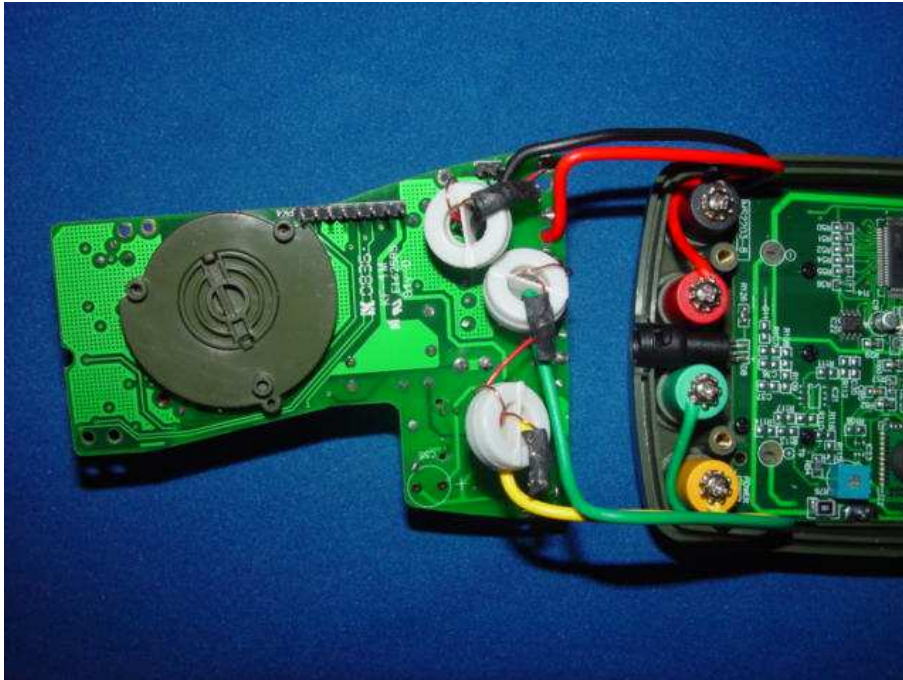

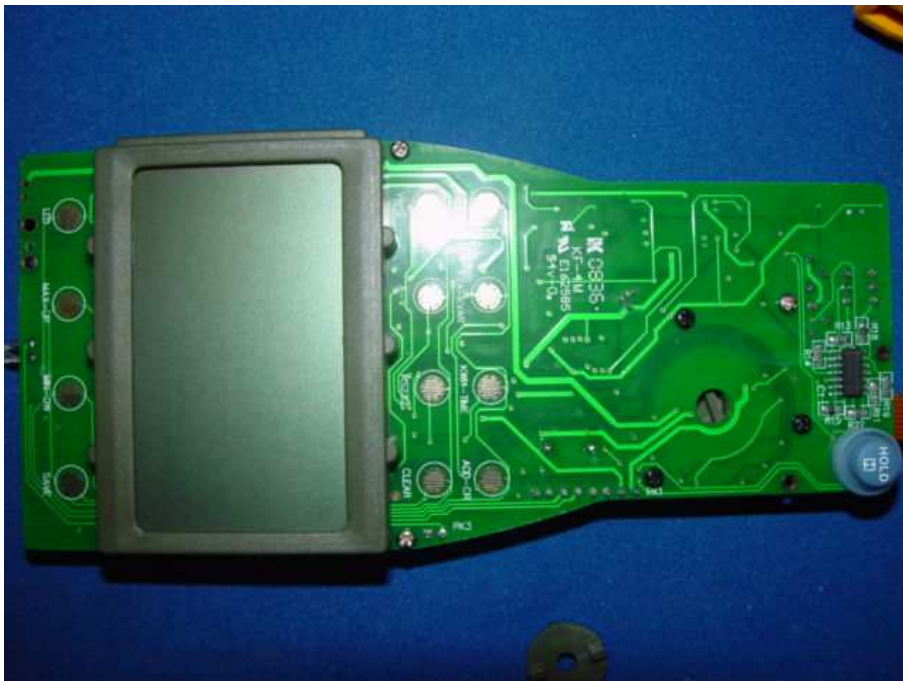
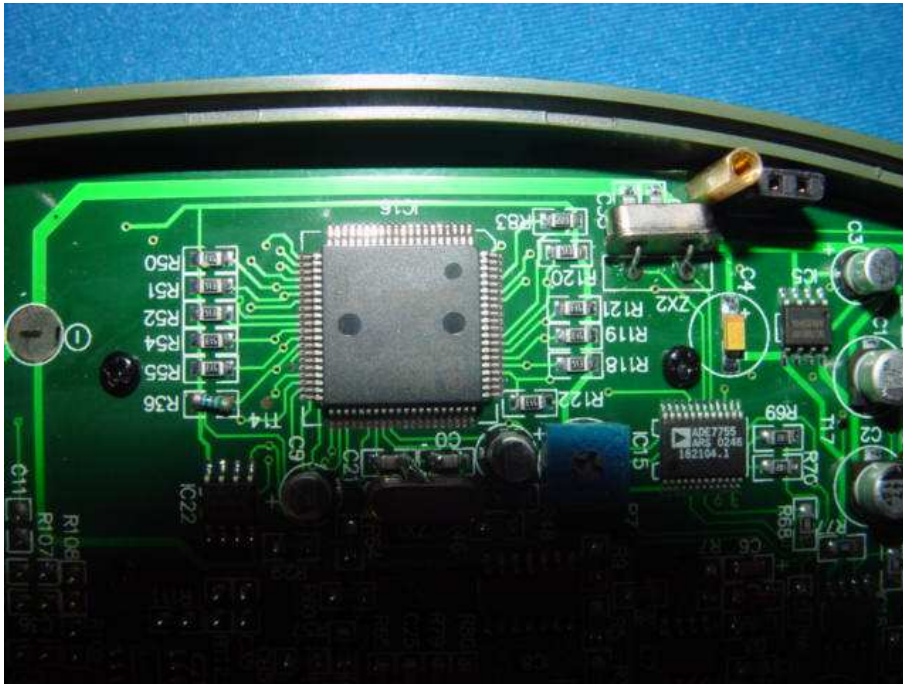

Outside
MS2205



MS2203

